

PTFF-050SH

PRECIOUS METAL BRUSHED DC MICRO MOTOR



27Lx16Wx12mmH (1.06Lx0.63Wx0.47inH)

VOLTAGE	1.5~9.0V
HOUSING LENGTH	26.7mm (1.05in)
WIDTH X HEIGHT	15.5 x 12mm (0.61 x 0.47in)
SHAFT LENGTH	39mm (1.54in)
SPEED (NO LOAD)	3000~8500 RPM
POWER (AT MAX EFF)	0.092~0.61W
TORQUE (AT MAX EFF)	3.0~7.0 g·cm (0.29~0.69 mN·m)
OPERATING TEMPERATURE	-20°C ~+60°C
WEIGHT	18g (0.63oz)

MODEL NUMBER	VOLTAGE (V)		NO LOAD		AT MAXIMUM EFFICIENCY					STARTING		
	OPERATING RANGE	NOMINAL	SPEED	CURRENT	SPEED	CURRENT	TORQUE	OUTPUT	TORQUE	CURRENT		
			RPM	A	RPM	A	g·cm	mN·m	W	g·cm	mN·m	A
PTFF-050SH-11170	1.5~9.0	7.0	10300	0.046	8500	0.17	7.0	0.69	0.610	46.0	4.51	0.82
PTFF-050SH-13130	2.0~4.0	2.0	3700	0.038	3000	0.11	3.0	0.29	0.092	17.0	1.67	0.40
	2.0~4.0	4.0	7600	0.050	6300	0.20	6.0	0.59	0.390	35.0	3.43	0.82

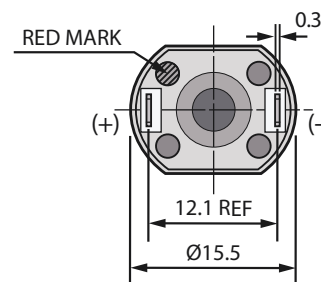
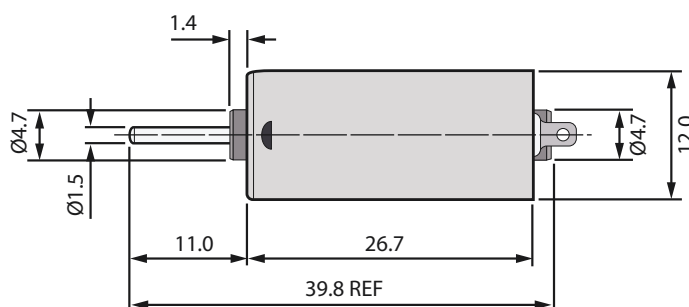
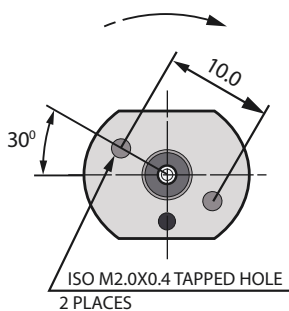

UNIT: mm

