

PTFC-130SA

CARBON BRUSHED DC MICRO MOTOR



25Lx20Wx15mmH (0.98Lx0.79Wx0.59inH)

VOLTAGE	9.0~15.0V
HOUSING LENGTH	25mm (0.88in)
WIDTH X HEIGHT	20.4 x 15.3mm (0.80 x 0.60in)
SHAFT LENGTH	38.0mm (1.5in)
SPEED (NO LOAD)	8254 RPM
POWER (AT MAX EFF)	1.03W
TORQUE (AT MAX EFF)	15.2 g·cm (1.49 mN·m)
OPERATING TEMPERATURE	-40°C ~+80°C
WEIGHT	24g (0.85oz)

MODEL NUMBER	VOLTAGE (V)		NO LOAD		AT MAXIMUM EFFICIENCY				STARTING		
	OPERATING RANGE	NOMINAL	SPEED RPM	CURRENT A	SPEED RPM	CURRENT A	TORQUE g·cm mN·m	OUTPUT W	TORQUE g·cm mN·m	CURRENT A	
PTFC-130SA-09450	9.0~15.0	13.0	8254	0.047	6325	0.156	15.2 1.49	1.03	65.04 6.37	0.513	

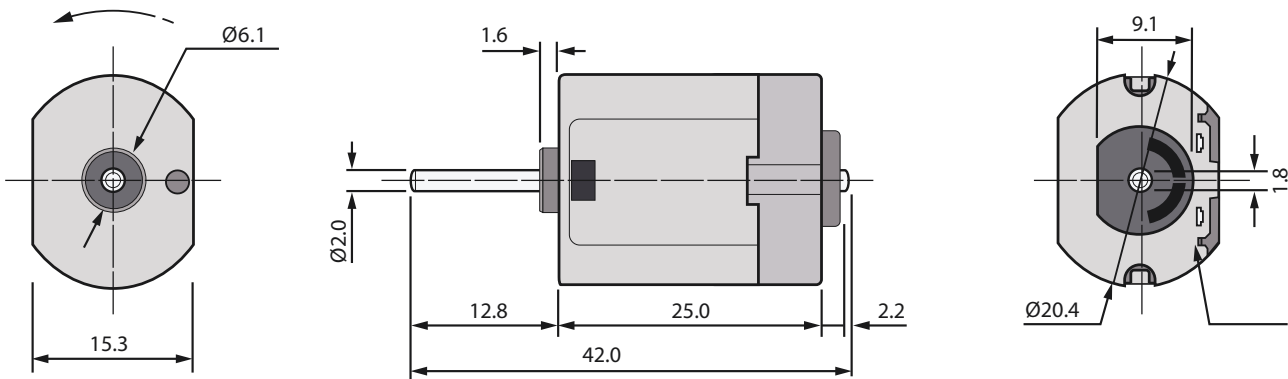

UNIT: mm

