

PTRS-360SM

CARBON BRUSHED DC MICRO MOTOR



28D x 33mmL (1.10D x 1.30inL)

VOLTAGE	3.0~8.0V
HOUSING LENGTH	32.6mm (1.28in)
DIAMETER	27.7mm (1.09in)
SHAFT LENGTH	47.0mm (1.85in)
SPEED (NO LOAD)	13700 RPM
POWER (AT MAX EFF)	5.43W
TORQUE (AT MAX EFF)	47.2 g·cm (4.64 mN·m)
OPERATING TEMPERATURE	-30°C ~+70°C
WEIGHT	55g (1.94oz)

MODEL NUMBER	VOLTAGE (V)		NO LOAD		AT MAXIMUM EFFICIENCY					STARTING		
	OPERATING RANGE	NOMINAL	SPEED RPM	CURRENT A	SPEED RPM	CURRENT A	TORQUE g·cm	TORQUE mN·m	OUTPUT W	TORQUE g·cm	TORQUE mN·m	CURRENT A
PTRS-360SM-2885	3.0~8.0	6.0	13700	0.38	11210	1.71	47.2	4.64	5.43	270	25.5	7.70

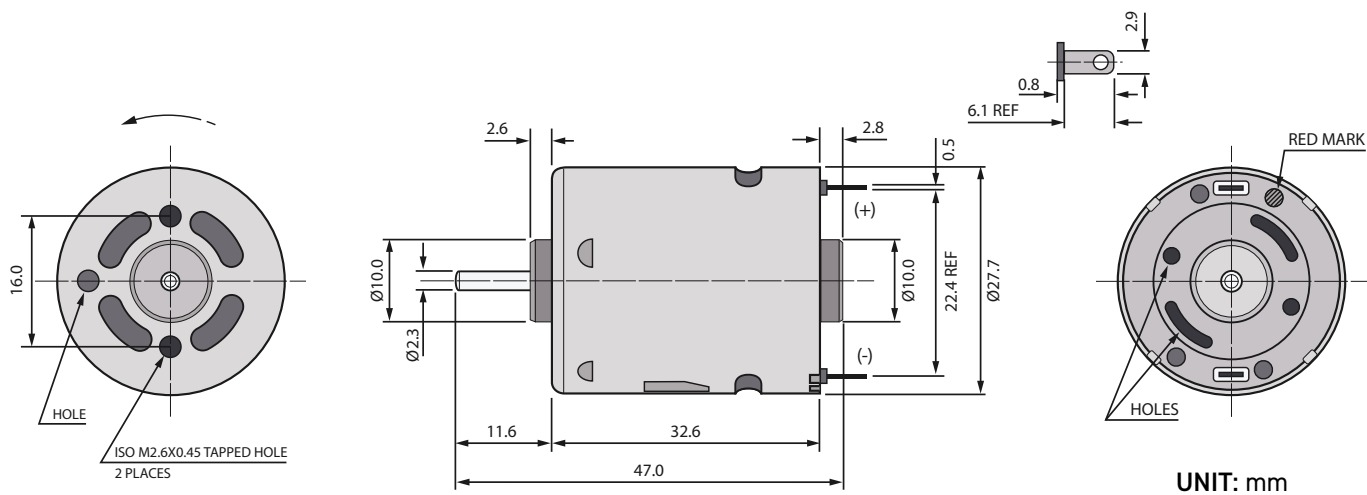

UNIT: mm

