

# PTRS-390SM

CARBON BRUSHED DC MICRO MOTOR



28D x 47mmL (1.10D x 1.85inL)

VOLTAGE	21.0~27.0V
HOUSING LENGTH	46.8mm (1.84in)
DIAMETER	27.7mm (1.09in)
SHAFT LENGTH	75.0mm (2.95in)
SPEED (NO LOAD)	6000 RPM
POWER (AT MAX EFF)	4.89W
TORQUE (AT MAX EFF)	91.5 g·cm (8.93 mN·m)
OPERATING TEMPERATURE	-30°C ~+80°C
WEIGHT	50g (1.76oz)

MODEL NUMBER	VOLTAGE (V)		NO LOAD		AT MAXIMUM EFFICIENCY					STARTING		
	OPERATING RANGE	NOMINAL	SPEED	CURRENT	SPEED	CURRENT	TORQUE		OUTPUT	TORQUE		CURRENT
			RPM	A	RPM	A	g·cm	mN·m	W	g·cm	mN·m	A
PTRS-390SM-16260	21.0~27.0	24.0	6000	0.041	5233	0.28	91.5	8.93	4.89	712.5	69.83	1.91

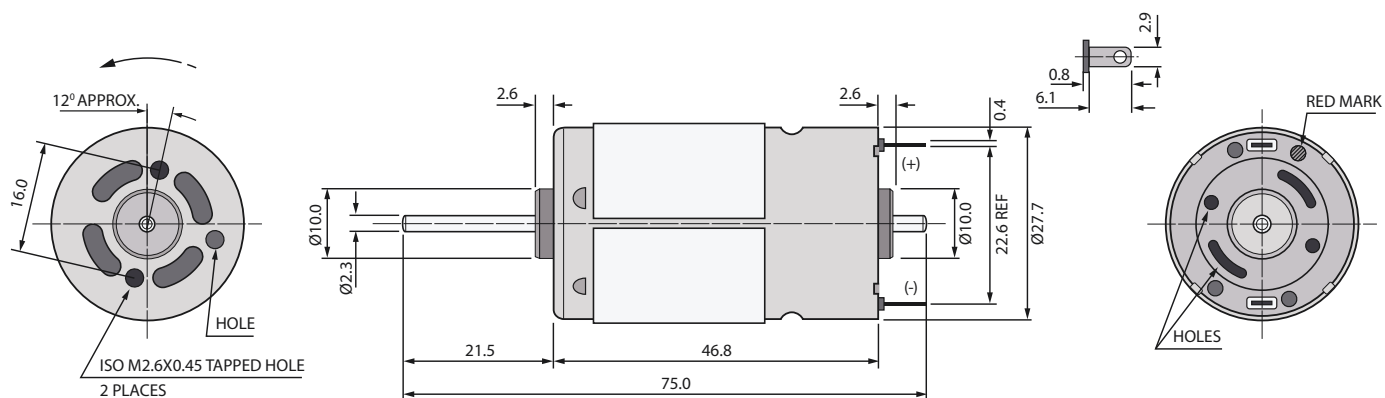

UNIT: mm

