

PTRS-550SA

CARBON BRUSHED DC MICRO MOTOR



38D x 57mmL (1.50D x 2.24inL)

VOLTAGE	10.0~18.0V
HOUSING LENGTH	57.0mm (2.24in)
DIAMETER	37.6mm (1.48in)
SHAFT LENGTH	75.0mm (2.95in)
SPEED (NO LOAD)	5450 RPM
POWER (AT MAX EFF)	10.45W
TORQUE (AT MAX EFF)	209.6 g·cm (20.54 mN·m)
OPERATING TEMPERATURE	-30°C ~+80°C
WEIGHT	211g (7.44oz)

MODEL NUMBER	VOLTAGE (V)		NO LOAD		AT MAXIMUM EFFICIENCY					STARTING		
	OPERATING RANGE	NOMINAL	SPEED RPM	CURRENT A	SPEED RPM	CURRENT A	TORQUE g·cm	TORQUE mN·m	OUTPUT W	TORQUE g·cm	TORQUE mN·m	CURRENT A
PTRS-550SA-31145	10.0~18.0	15.0	5450	0.16	4661	0.94	209.6	20.54	10.45	1456	142.7	5.58

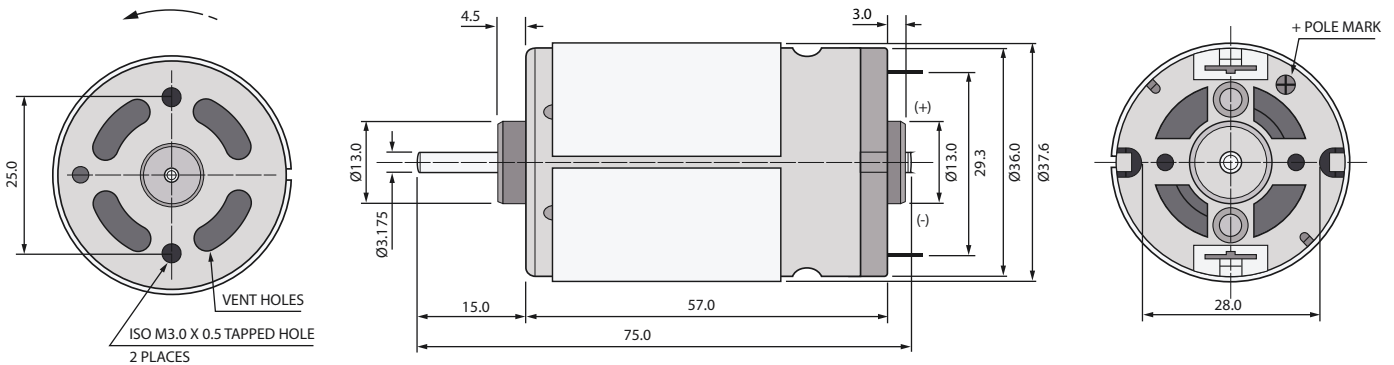

UNIT: mm

