

PTFF-K20

PRECIOUS METAL BRUSHED DC MICRO MOTOR



15Lx8Wx6mmH (0.59Lx0.32Wx0.24inH)

VOLTAGE	2.5~4.0V
HOUSING LENGTH	14.5mm (0.57in)
WIDTH X HEIGHT	8mm x 6mm (0.32 x 0.24in)
SHAFT LENGTH	19.5mm (0.77in)
SPEED (NO LOAD)	23800 RPM
POWER (AT MAX EFF)	0.25W
TORQUE (AT MAX EFF)	1.25 g·cm (0.123 mN·m)
OPERATING TEMPERATURE	-20°C ~+60°C
WEIGHT	2.4g (0.08oz)

MODEL NUMBER	VOLTAGE (V)		NO LOAD		AT MAXIMUM EFFICIENCY					STARTING		
	OPERATING RANGE	NOMINAL	SPEED	CURRENT	SPEED	CURRENT	TORQUE		OUTPUT	TORQUE		CURRENT
			RPM	A	RPM	A	g·cm	mN·m	W	g·cm	mN·m	A
PTFF-K20-08130	2.5~4.0	3.5	23800	0.42	18700	0.151	1.25	0.123	0.25	5.82	0.57	0.55

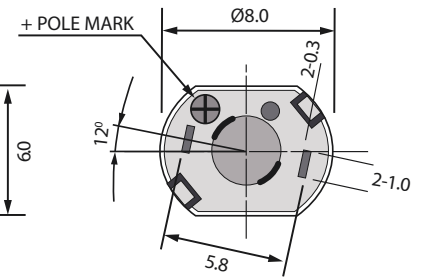
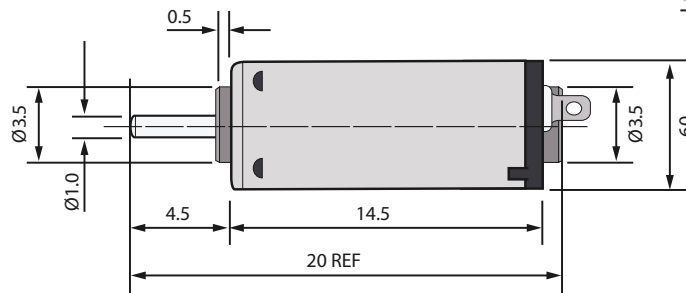
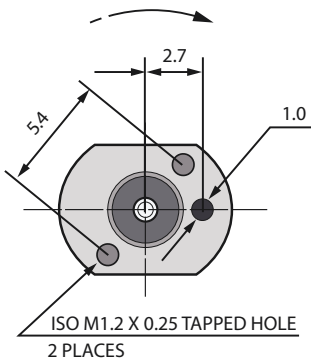

UNIT: mm

