

PTFF-M20

PRECIOUS METAL BRUSHED DC MICRO MOTOR



15Lx10Wx8mmH (0.59Lx0.39Wx0.31inH)

VOLTAGE	1.2~4.0V
HOUSING LENGTH	14.9mm (0.59in)
WIDTH X HEIGHT	10mm x 8mm (0.39 x 0.31in)
SHAFT LENGTH	19.6mm (0.77in)
SPEED (NO LOAD)	8000~15800 RPM
POWER (AT MAX EFF)	0.06~0.23W
TORQUE (AT MAX EFF)	0.96~1.80 g·cm (0.094~0.180 mN·m)
OPERATING TEMPERATURE	-20°C ~+60°C
WEIGHT	4g (0.14oz)

MODEL NUMBER	VOLTAGE (V)		NO LOAD		AT MAXIMUM EFFICIENCY					STARTING		
	OPERATING RANGE	NOMINAL	SPEED	CURRENT	SPEED	CURRENT	TORQUE		OUTPUT	TORQUE		CURRENT
			RPM	A	RPM	A	g·cm	mN·m	W	g·cm	mN·m	A
PTFF-M20-08130	2.0~3.0	3.0	15200	0.045	11820	0.160	1.70	0.160	0.20	7.6	0.74	0.55
PTFF-M20-10100	1.2~3.5	2.4	15800	0.056	12410	0.200	1.80	0.180	0.23	8.6	0.84	0.75
PTFF-M20-07170	2.0~4.0	2.0	8000	0.025	6020	0.076	0.96	0.094	0.06	3.9	0.38	0.23

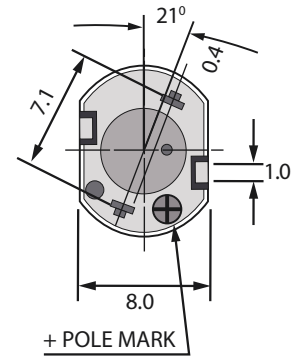
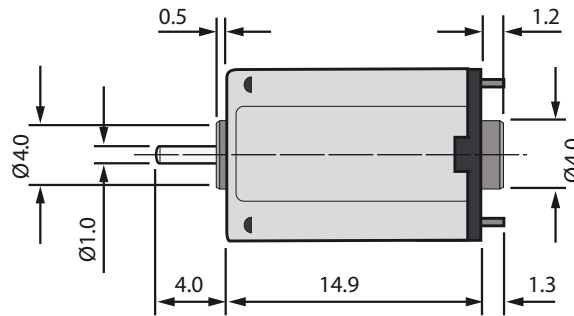
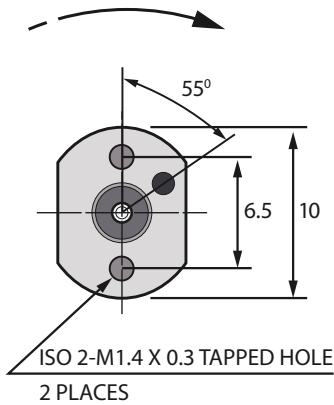

UNIT: mm

