

**AC** Forward Curve Dual Inlet

# FS320 Series Centrifugal Fan

320mm (12.6in)



## GENERAL SPECIFICATIONS

- Impeller:** Galvanized Steel
- Life:** 40,000 hours
- IP Rating:** IP44
- Operating Temp:** -25°C~+40°C
- Bearings:** Ball

## FEATURES

- High efficiency inlet design
- Lubricated maintenance-free ball bearings
- Vibration-free operation
- Precision balanced for superior performance
- Compact and rugged construction

model	voltage (V)	freq (Hz)	current (A)	power (W)	speed (RPM)	airflow (m <sup>3</sup> /h)	airflow (CFM)	pressure (Pa)	capacitor (μF)	insulation class
FS320A	400	50	7.5	4000	1390	1800	1059	/	/	F

## Performance Curves

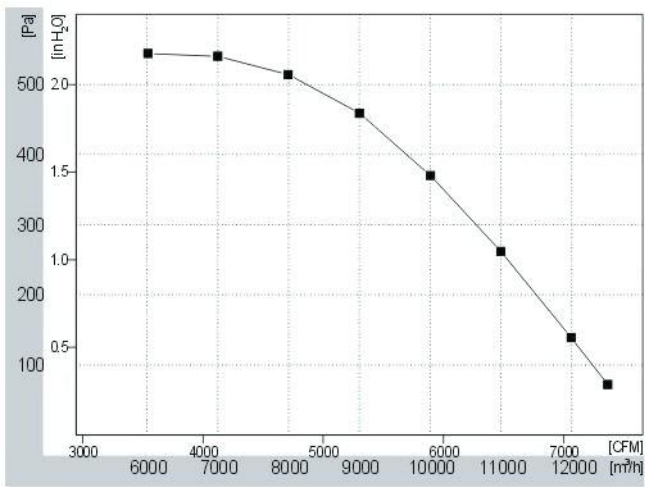

## Dimensions (mm)

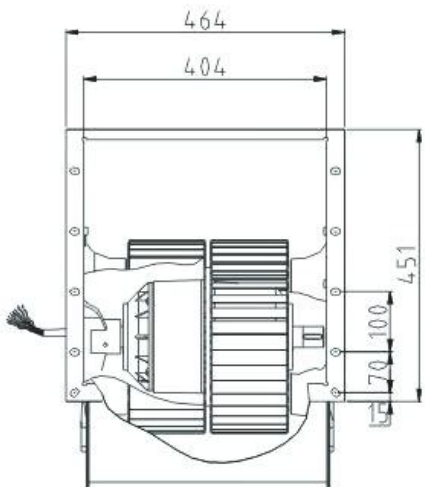
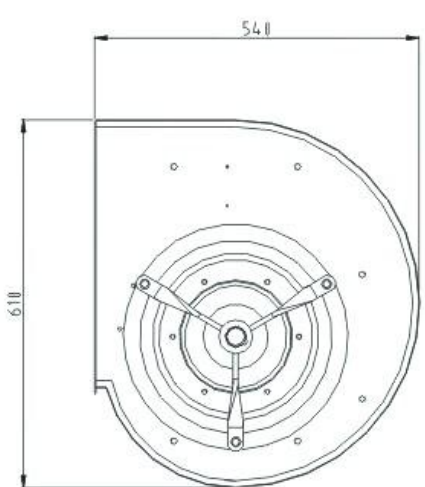

## Applications

HVAC, cabinet cooling, medical equipment, military applications, air filtration, semiconductors, commercial and industrial cooling.



T 1.888.546.0524 • F 1.610.647.0319  
 email: sales@pelonistech.com • www.pelonistech.com

