

PTF-PE SERIES

ECO-WATT Mixed-Flow Inline Duct Fans

PTF-PE series Eco-Watt Mixed Flow Inline Duct Fans include EC motor technology with ultra-low power consumption and variable speed control.

Each fan body is made of lightweight environmentally friendly double-insulation material. The innovative hydro mechanical design ensures optimal airflow and pressure, high operating efficiency, and low noise and the special joint design facilitates easy installation and maintenance.

Additional features can also be added including a user-friendly timer, temperature sensor, humidity sensor, and other custom features.

The fans can operate from -20°C to 60°C and include thermal protection and dual ball bearings for long-life operation up to 50,000 hours. Protection Class:IP44.

Model	Voltage (V)	Current (A)	Power (W)	Speed (RPM)	Airflow (CFM)	Airflow (m³/h)	Pressure (inH ₂ O)	Pressure (mmAq)	Pressure (Pa)	Weight (kg)
PTF-100PE	100~240V	0.47 MAX 0.94	70	3800	215	366	2.32	58.93	577.30	1.5
PTF-125PE	100~240V	0.47 MAX 0.94	70	3800	330	561	2.06	52.32	512.61	1.5
PTF-150PE	220~240V	0.35	50	2250	312	530	1.41	35.81	350.86	2.3
	100~240V	0.47 MAX 0.94	70	3000	381	647	2.02	51.31	253.82	
PTF-200PE	100~120V 220~240V	2.1 1.05	165	3000	736	1250	3.00	76.20	746.52	4.9
PTF-250PE	100~240V	1.50 MAX 2.70	255	3000	972	1652	4.26	108.20	1060.06	6.0
PTF-315PE	100~240V	1.50 MAX 2.70	250	2350	1298	2206	3.29	83.57	818.68	8.0

*The rated rotor speed can be customized.

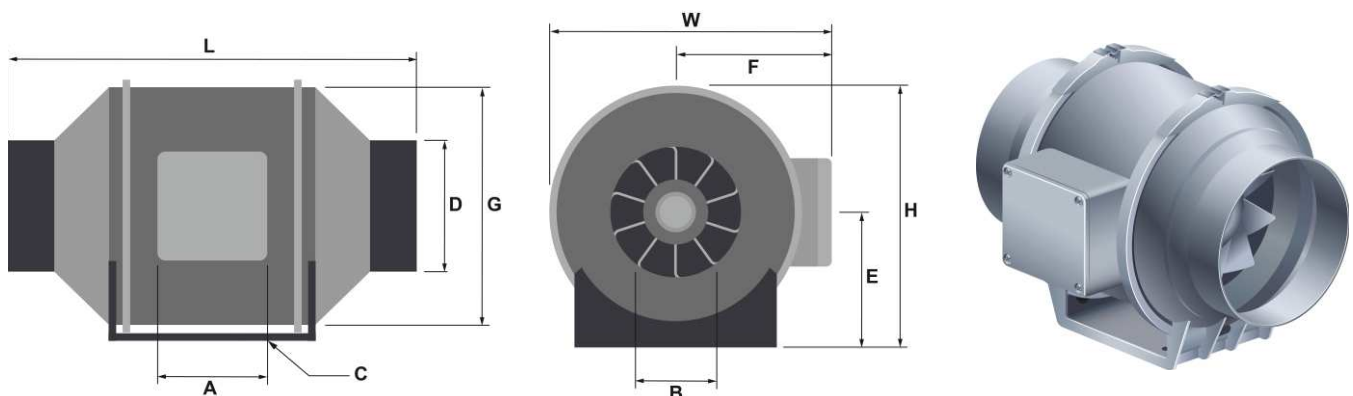

MODEL	A	B	C	ΦD	E	F	ΦG	L	W	H
PTF-100PE	80 (3.15)	60 (2.36)	4-Φ4.5	97 (3.82)	99 (3.90)	116 (4.57)	163 (6.42)	302 (11.89)	204 (8.03)	195 (7.68)
PTF-125PE	80 (3.15)	60 (2.36)	4-Φ4.5	123 (4.84)	99 (3.90)	116 (4.57)	163 (6.42)	257 (10.12)	204 (8.03)	195 (7.68)
PTF-150PE	80 (3.15)	60 (2.36)	4-Φ5.0	147 (5.79)	109 (4.23)	127 (5.00)	187 (7.36)	313 (12.32)	227 (8.94)	208 (8.19)
PTF-200PE	100 (3.94)	94 (3.70)	4-Φ5.5	197 (7.76)	125 (4.92)	137 (5.34)	205 (8.07)	302 (11.89)	249 (9.80)	237 (9.33)
PTF-250PE	150 (5.91)	150 (5.91)	4-Φ8*11	247 (9.72)	150 (5.91)	174 (6.85)	261 (10.28)	383 (15.08)	310 (12.20)	286 (11.26)
PTF-315PE	181 (7.13)	178 (7.01)	4-Φ8*11	312 (12.28)	187 (7.36)	216 (8.50)	325 (12.80)	446 (17.56)	386 (15.20)	357 (14.06)