

# PTI-AE SERIES

## ECO-WATT Inline Duct Fans

PTI-AE series Eco-Watt Inline Duct Fans include EC motor technology with ultra-low power consumption and variable speed control.

Each fan body is made of lightweight environmentally friendly double-insulation material.

The innovative impeller design ensures optimal airflow and pressure, high operating efficiency, and low noise, and the special joint design facilitates easy installation and maintenance.

The fans can operate from -20°C to 60°C and include thermal protection and dual ball bearings for long-life operation up to 50,000 hours.

Protection Class:IP44.

Model	Voltage (V)	Current (A)	Power (W)	Speed (RPM)	Airflow (CFM)	Airflow (m <sup>3</sup> /h)	Pressure (inH <sub>2</sub> O)	Pressure (mmAq)	Pressure (Pa)	Weight (kg)
PTI-160AE	220~240V	0.70 MAX 1.40	77	4300	470	798	2.18	55.37	542.47	2.0
PTI-200AE	220~240V	1.00	110	3500	760	1292	1.95	49.53	485.24	2.7

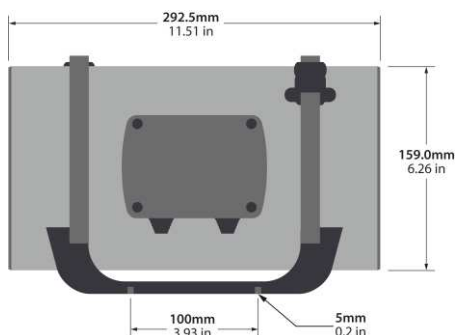
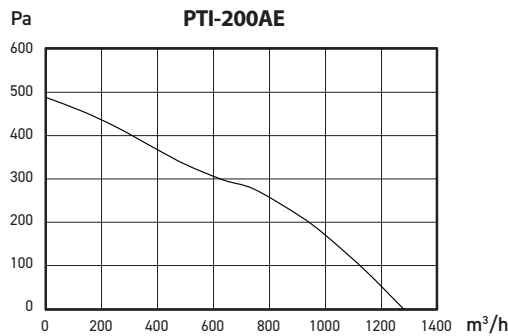
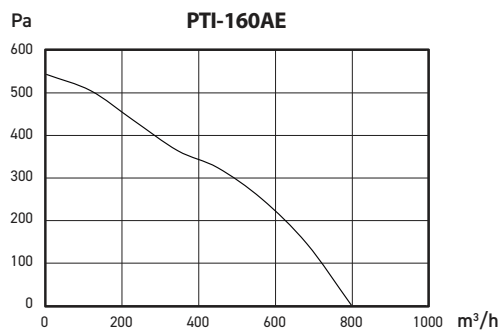

**PTI-160AE**

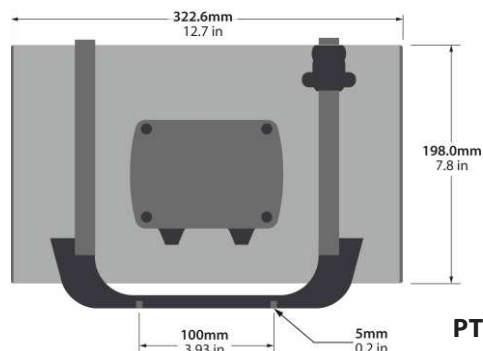
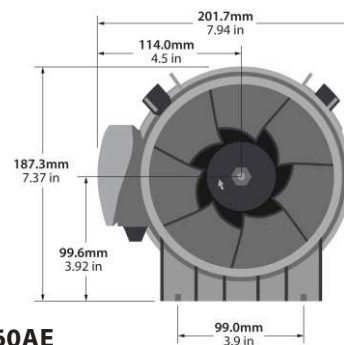

**PTI-200AE**

