

TITAN[®] DC BLOWERS

DESIGNED FOR RUGGED ALL-WEATHER COOLING



PELONISTECHNOLOGIES.COM

PTI **PELONIS**
TECHNOLOGIES INC.



TITAN® DC blowers are made for applications that require high performance cooling and protection from harsh weather conditions in outdoor and extreme environments. These rugged cooling products are also designed with “Intelligent Motion Controls” that improve efficiency and long-term reliability.

RUGGED DESIGN FOR EFFECTIVE COOLING

TITAN® DC blowers ensure effective cooling via their innovative multi-blade impellers and aluminum alloy die cast base designs that absorb and disperse heat effectively. They also include a single coil differential drive that is incorporated into the internal electronics to maximize airflow and pressure.

INTELLIGENT MOTION CONTROL

Each TITAN® blower model includes standard protection that enables the unit to restart if the impeller is blocked. Optional features include other “Intelligent Motion Controls” that can be added to the electronics to take full advantage of the blower’s performance and efficiency capabilities. These features include tachometer, rotation detection, life detection, pulse width modulation, automatic temperature control, current limit control, constant speed control, multiple alarm connections, and others. Various controls can also be programmed for custom output.

DUST & MOISTURE PROTECTION

IP51, IP54, IP56, or IP67 levels of dust and moisture protection can be applied to each blower’s exposed areas and internal electronics to protect applications that are used in severe to very harsh environmental conditions.

STANDARD FEATURES & SPECIFICATIONS

- 53 x 31mm, 120 x 32mm, and 193 x 72mm sizes
- 12V, 24V, 48V
- 5~128 CFM (0.14~3.62 m³/min)
- Dual Ball Bearings
- Aluminum Die Cast Base
- Lead Wires UL1007, 24 AWG
- Auto Restart
- Locked Rotor Protection
- IP51 Dust & Moisture Protection
- Operating Temp -10°C to +70°C
- Operating Life 70,000 hours
- RoHS Compliant
- UL, cUL, CE

APPLICATIONS

HVAC
Compact Electronics
Medical Devices
Industrial Automation
Satellite Equipment
Automotive Products

TITAN® DC blowers provide effective cooling in harsh environments and can be customized with optional controls and features that improve performance and efficiency to meet the most demanding requirements.

For additional information or for assistance with your application, contact us at sales@pelonistech.com.

CONTENTS

Series	Size (mm)	Size (in)	Airflow (CFM)	Airflow (m ³ /min)	Page
K5331-37	53 x 31	2.09 x 1.22	5~16	0.14~0.45	1-3
P1232-28	120 x 32	4.72 x 1.26	23~43	0.65~1.22	4-6
P1970-38	193 x 72	7.60 x 2.83	85~128	2.41~3.62	7-9
Intelligent Motion Controls and Environmental Protection Features					10

53 x 31mm



K5331-37

- 53 x 53 x 31mm (2.09 x 2.09 x 1.22in)
- 12V, 24V
- 5~16 CFM (0.14~0.45 m³/min)
- Dual Ball Bearings
- 37-Blade Impeller
- Aluminum Die Cast Base
- Frame/Impeller: PC/ABS + 20% GF,UL94-V0
- Lead Wires: UL (+) Red; (-) Black, 24 AWG, 300±10mm
- Operating Temperature: -10°C ~ +70°C
- Operating Life: 70,000 hours
- UL, cUL, CE



Model Number	Curve	Voltage (V)	Range (VDC)	Label (A)	Current (A)	Power (W)	Speed (RPM)	Airflow (Q) (CFM) (m ³ /min)	Pressure (P) (mmAq) (inH ₂ O)	Noise (dBA)
K5331Y12BALB1b-37	⑤	12	8~14	1.100	1.050	12.60	12000	16.35 0.46	36.24 1.43	52.45
K5331X12BALB1b-37	④	12	8~14	0.720	0.650	7.80	10000	13.62 0.39	25.16 0.99	47.70
K5331H12BALB1b-37	③	12	8~14	0.450	0.340	4.08	8000	10.90 0.31	16.10 0.63	41.89
K5331M12BALB1b-37	②	12	8~14	0.300	0.250	3.00	6000	8.17 0.23	9.06 0.36	34.39
K5331L12BALB1b-37	①	12	8~14	0.210	0.180	2.16	4000	5.45 0.15	4.03 0.16	23.82
K5331Y24BALB1b-37	⑤	24	15~27	0.680	0.540	12.96	12000	16.35 0.46	36.24 1.43	52.45
K5331X24BALB1b-37	④	24	15~27	0.450	0.330	7.92	10000	13.62 0.39	25.16 0.99	47.70
K5331H24BALB1b-37	③	24	15~27	0.240	0.180	4.32	8000	10.90 0.31	16.10 0.63	41.89
K5331M24BALB1b-37	②	24	15~27	0.170	0.130	3.12	6000	8.17 0.23	9.06 0.36	34.39
K5331L24BALB1b-37	①	24	15~27	0.110	0.090	2.16	4000	5.45 0.15	4.03 0.16	23.82

K5331-37

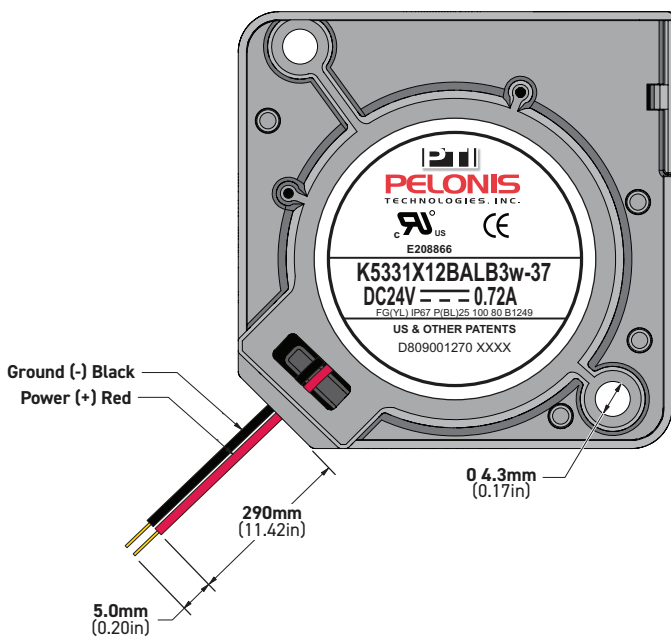
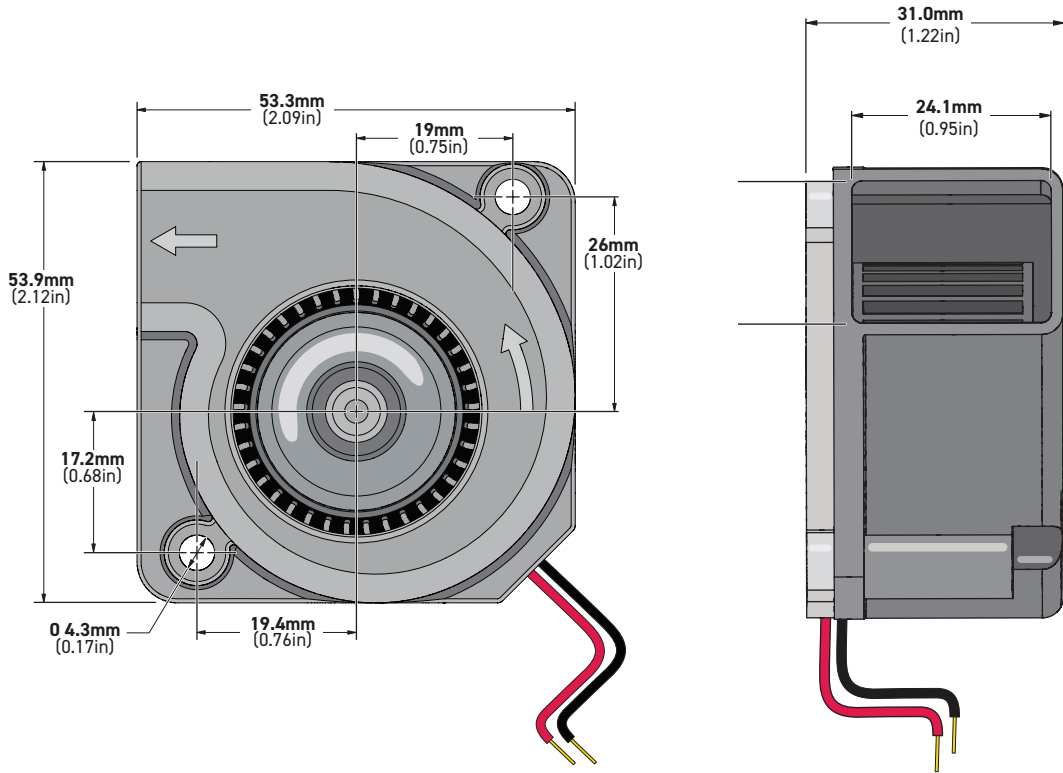



K5331-37

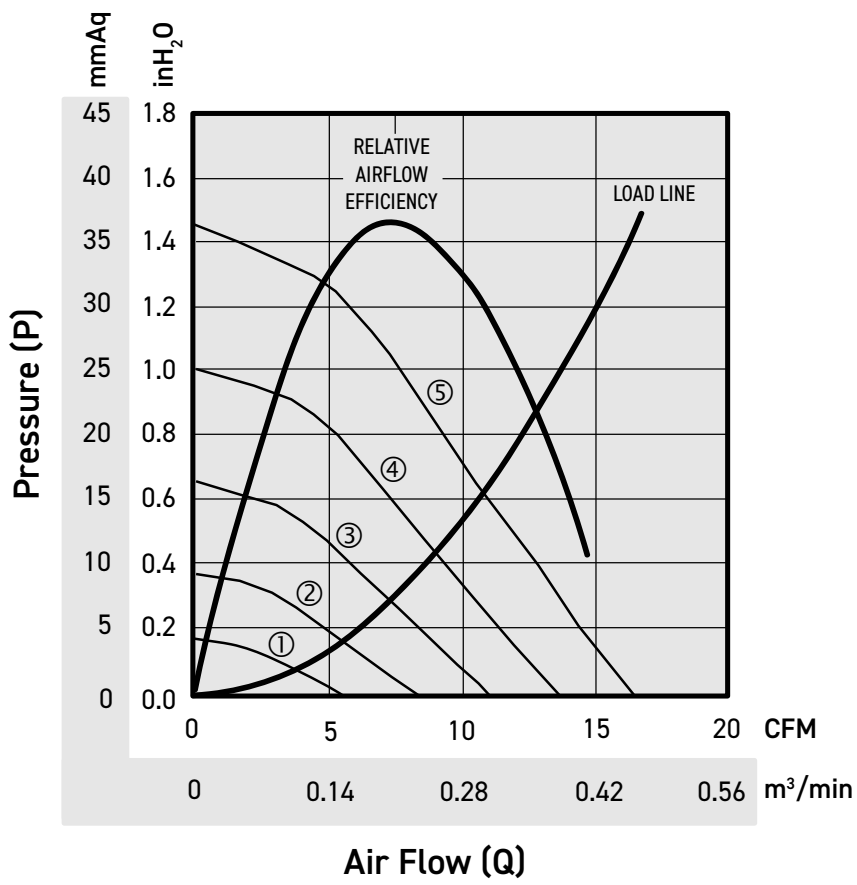

120 x 32mm



P1232-28

- 120 x 120 x 32mm (4.72 x 4.41 x 1.26in)
- 12V, 24V
- 23~43 CFM (0.65~1.22 m³/min)
- Dual Ball Bearings
- 28-Blade Impeller
- Aluminum AD12 Die Cast Base
- Frame/Impeller: Stainless Steel/PBT + 15% GF, UL94-V0
- Stainless Steel Air Inlet Guard (optional)
- Lead Wires: UL (+) Red; (-) Black, 24 AWG, 250±10mm
- Operating Temperature: -10°C ~ +70°C
- Operating Life: 70,000 hours
- UL, cUL, CE



Model Number	Curve	Voltage (V)	Range (VDC)	Label (A)	Current (A)	Power (W)	Speed (RPM)	Airflow (Q)		Pressure (P)		Noise (dBA)
								(CFM)	(m ³ /min)	(mmAq)	(inH ₂ O)	
P1232Y12BALB1b-28	⑤	12	7~14	3.250	1.700	20.40	5200	42.91	1.22	51.47	2.03	61.64
P1232X12BALB1b-28	④	12	7~14	2.132	1.350	16.20	4600	37.96	1.07	40.28	1.59	58.45
P1232H12BALB1b-28	③	12	7~14	1.261	0.940	11.28	4000	33.01	0.93	30.46	1.20	54.81
P1232M12BALB1b-28	②	12	7~14	0.806	0.577	6.92	3400	28.06	0.79	22.01	0.87	50.57
P1232L12BALB1b-28	①	12	7~14	0.442	0.322	3.86	2800	23.10	0.65	14.92	0.59	45.51
P1232Y24BALB1b-28	⑤	24	15~27	1.560	0.760	18.24	5200	42.91	1.22	51.47	2.03	61.64
P1232X24BALB1b-28	④	24	15~27	0.949	0.675	16.20	4600	37.96	1.07	40.28	1.59	58.45
P1232H24BALB1b-28	③	24	15~27	0.559	0.455	10.92	4000	33.01	0.93	30.46	1.20	54.81
P1232M24BALB1b-28	②	24	15~27	0.390	0.300	7.20	3400	28.06	0.79	22.01	0.87	50.57
P1232L24BALB1b-28	①	24	15~27	0.260	0.168	4.03	2800	23.10	0.65	14.92	0.59	45.51
P1232Y48BALB1b-28	⑤	48	30~57	0.560	0.400	19.20	5200	42.91	1.22	51.47	2.03	61.64
P1232X48BALB1b-28	④	48	30~57	0.420	0.336	16.13	4600	37.96	1.07	40.28	1.59	58.45
P1232H48BALB1b-28	③	48	30~57	0.290	0.221	10.61	4000	33.01	0.93	30.46	1.20	54.81
P1232M48BALB1b-28	②	48	30~57	0.190	0.150	7.20	3400	28.06	0.79	22.01	0.87	50.57
P1232L48BALB1b-28	①	48	30~57	0.120	0.084	4.03	2800	23.10	0.65	14.92	0.59	45.51

P1232-28

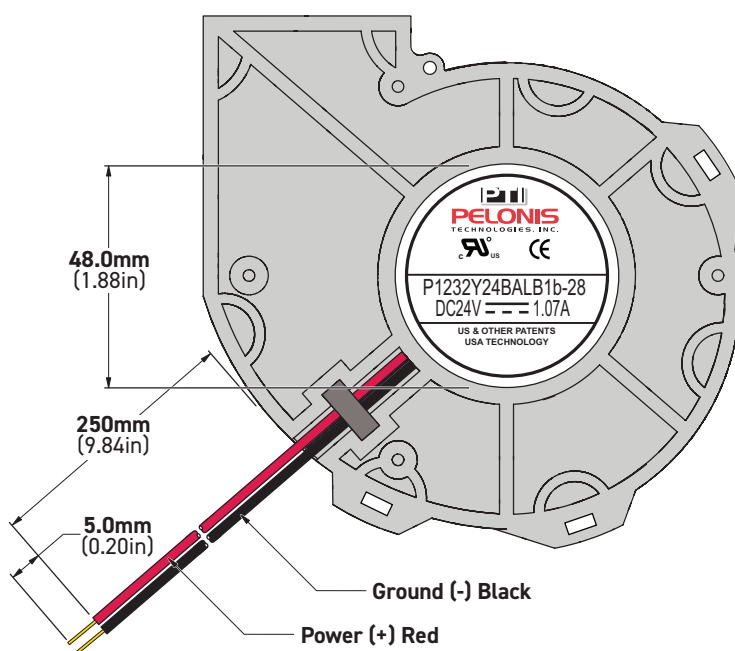
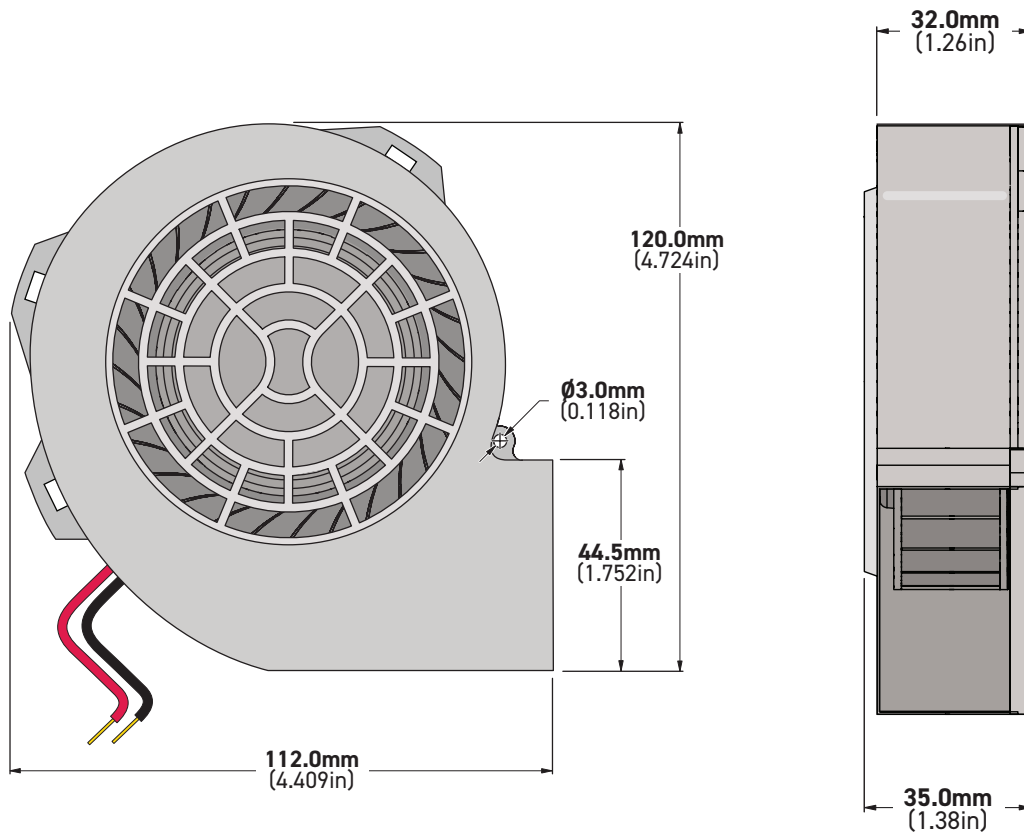

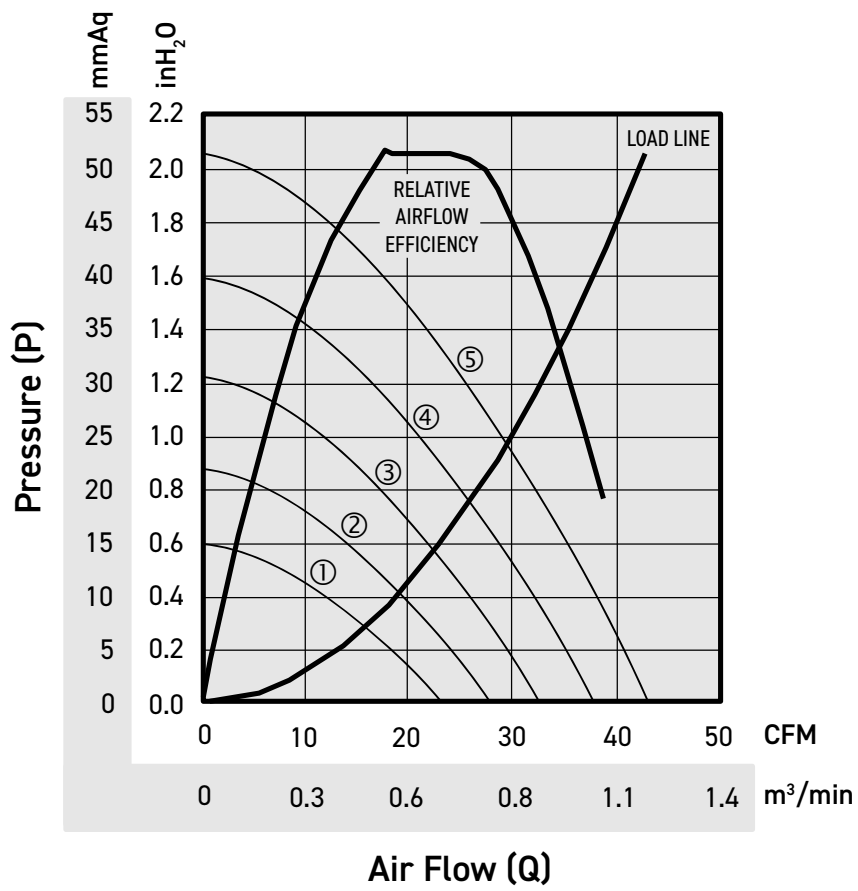

193 x 72mm



P1970-38

- 193 x 177 x 72mm (7.60 x 6.97 x 2.83in)
- 12V, 24V, 48V
- 85~128 CFM (2.41~3.62 m³/min)
- Dual Ball Bearings
- 38-Blade Impeller
- Aluminum Die Cast Base
- Frame/Impeller: PC/Aluminum
- Air Inlet Guard (optional)
- Lead Wires: UL (+) Red; (-) Black, 24 AWG, 230±10mm
- Operating Temperature: -10°C ~ +70°C
- Operating Life: 70,000 hours
- UL, cUL, CE



Model Number	Curve	Voltage (V)	Range (VDC)	Label (A)	Current (A)	Power (W)	Speed (RPM)	Airflow (Q)		Pressure (P)		Noise (dBA)
								(CFM)	(m ³ /min)	(mmAq)	(inH ₂ O)	
P1970M12BALA1b-38	②	12	7~14	3.120	2.400	28.80	1500	106.43	3.01	35.68	1.40	50.70
P1970L12BALA1b-38	①	12	7~14	1.430	1.100	13.20	1200	85.15	2.41	22.83	0.90	44.90
P1970H24BALA1b-38	③	24	15~27	2.270	1.750	42.00	1800	127.72	3.62	51.37	2.02	55.50
P1970M24BALA1b-38	②	24	15~27	1.560	1.200	28.80	1500	106.43	3.01	35.68	1.40	50.70
P1970L24BALA1b-38	①	24	15~27	0.650	0.500	12.00	1200	85.15	2.41	22.83	0.90	44.90
P1970H48BALA1b-38	③	48	30~57	1.100	0.876	42.05	1800	127.72	3.62	51.37	2.02	55.50
P1970M48BALA1b-38	②	48	30~57	0.780	0.610	29.28	1500	106.43	3.01	35.68	1.40	50.70
P1970L48BALA1b-38	①	48	30~57	0.320	0.254	12.19	1200	85.15	2.41	22.83	0.90	44.90

P1970-38

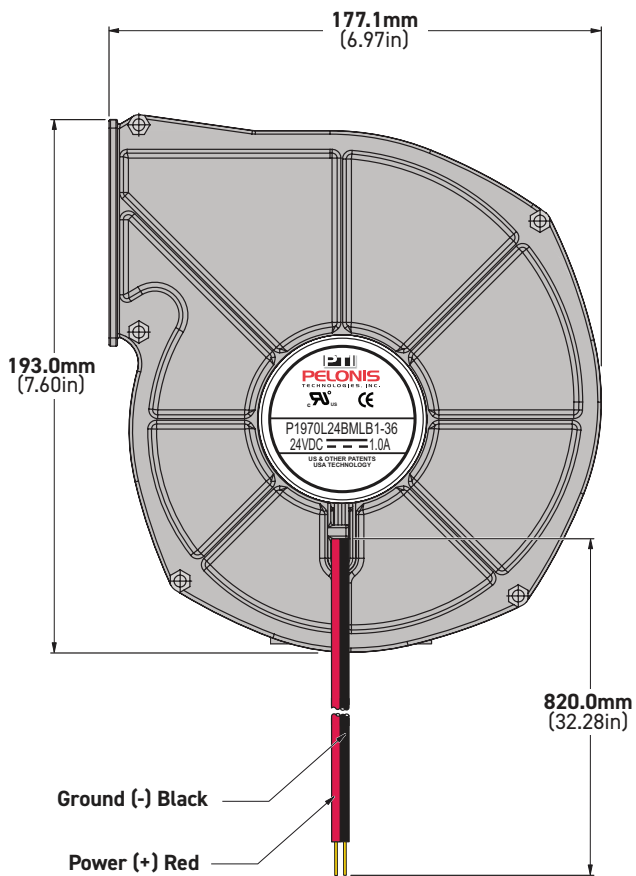
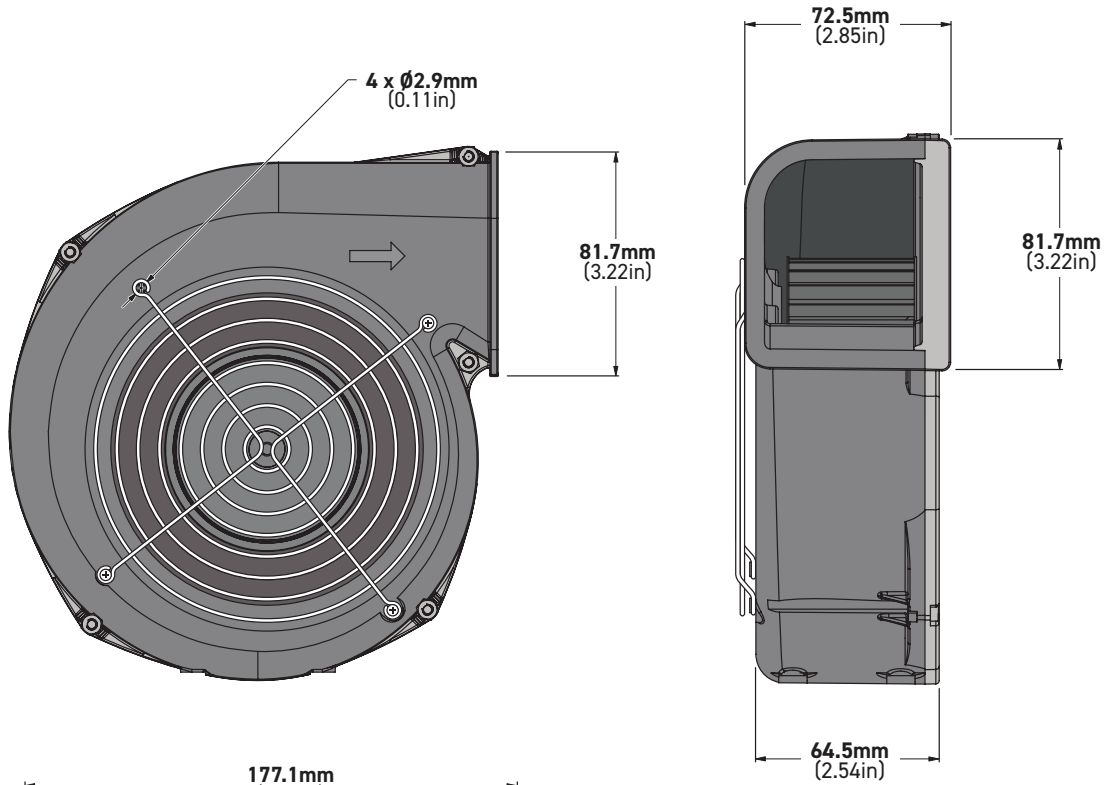

P1970-38

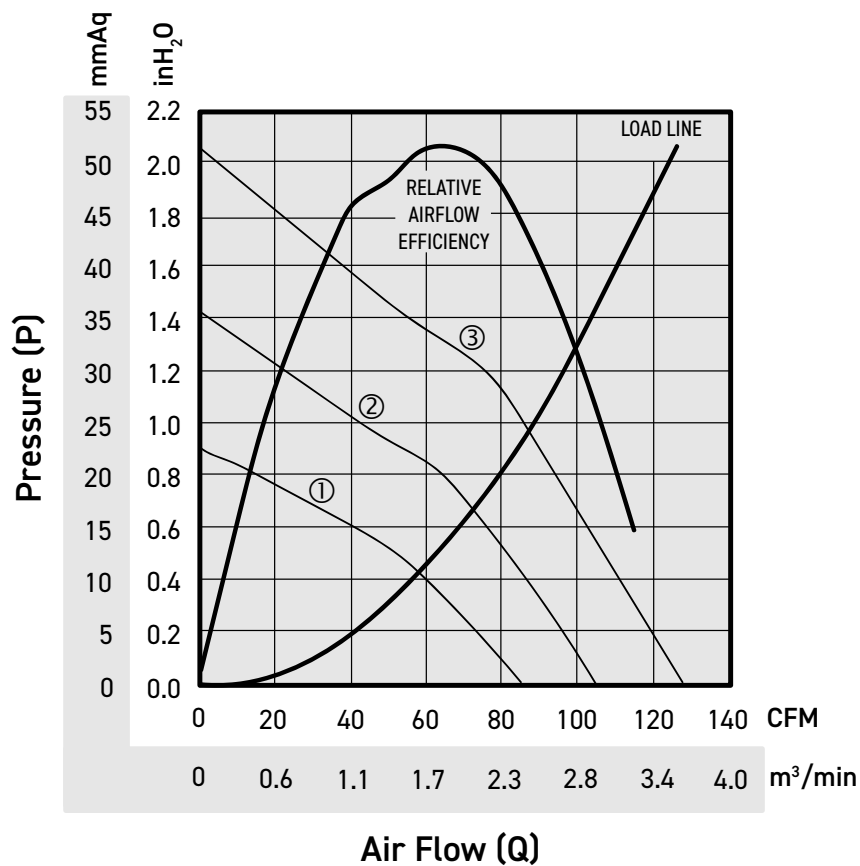

INTELLIGENT MOTION CONTROLS AND ENVIRONMENTAL PROTECTION FEATURES

CONTROL/FEATURE	STANDARD	OPTIONAL	#	CODE	DESCRIPTION	WIRE COLOR
Inrush Current Protection		■	1a	IR	Protects from Current surges. At startup, the current is applied gradually (soft start).	-
Auto Restart	■		1b	AS	The Current is reduced to zero when the blower is blocked and the blower attempts to restart every few seconds.	-
Tachometer (Frequency Generator)		■	2a	FG	An output signal is provided in order to monitor the blower's running speed.	Yellow
Rotation Detector		■	2b	RD	Detects whether the blower is rotating. A LOW output signal indicates that the blower is rotating.	Gray
Rotation Detector Complement		■	2c	RDb	Detects whether the blower is rotating. A HIGH output signal indicates that the blower is rotating.	Violet
Life Detection		■	2d	LD	LOW output signal indicates RPM is <70% of rated speed (indicates aging blower of many connected in parallel).	Brown
Life Detection Complement		■	2e	LDb	This function is the complement of the LD Control applied in one blower.	Brown
DC Voltage Signal Control		■	3a	VPWM	The blower speed is controlled by applying a DC Voltage signal. Standard DC signal is 0 to 5V.	White
DC Current Signal Control		■	3b	IPWM	The blower speed is controlled by applying a DC Current signal (e.g. 4 to 20mA or 20 to 50mA).	White
Pulse Width Modulation Control		■	3c	PPWM	The blower speed is controlled by applying a PWM signal with frequency from 30Hz to 30KHz.	Blue
Automatic Temperature Control		■	5a	TPWM	The blower speed is controlled by temperature sensed by a Thermistor (NTC). Standard NTC 100K@25C, B=4484.	Green
Variable Resistor Control		■	5b	RPWM	The blower speed is controlled by manually varying the external resistor (Min VR = 10K, Max VR = 100K).	Orange + White
Current Limit Protection		■	6	CL	The current is limited at startup mode (typically less than twice the rated current).	-
Fixed Constant Speed		■	7	CS _f	The blower speed is independent of the power supply above the rated voltage (factory preset).	-
Programmable Constant Speed		■	7a	CS _p	The desired maximum fan speed can be selected externally for less than the rated values.	Orange + White
Multi-Blower Alarm Connection		■	-	-	Alarm indicator when any blower has stopped running in an array of connected blowers.	-
IP51 Protection	■		w	IP51	Limited protection from dust and condensation.	-
IP54 Protection		■	w	IP54	Protection from dust and water spray from any direction.	-
IP56 Protection		■	w	IP56	Protection from dust and high pressure water jets from any direction.	-
IP67 Protection		■	w	IP67	Total protection from dust and water immersion.	-

INNOVATION IN MOTION



1.888.546.0524 | 1.610.594.6000 | SALES@PELONISTECH.COM | PELONISTECHNOLOGIES.COM